

GENERAL STRUCTURAL NOTES

- CODE:
 - 2006 International Building Code
 - 2007 California Building Code
 - 2001 American Iron and Steel Institute Handbook of Cold-Formed Steel Design
- LOADS:
 - Roof Live Load = 20 PSF (Red)
 - Basic Wind Speed = 90 mph, Importance Factor (I) = 1.0, Exposure = C
 - Occupancy Category = II, Seismic Design Category = D
 - Basic Seismic - Force - resisting System:
 - Lateral : Cantilevered Columns
 - Longitudinal: Cantilevered Columns
 - Analysis Procedure: Equivalent Lateral Force Procedure
- FOUNDATIONS:
 - Allowable soil bearing value is 1500 PSF at 18" below finish grade or existing natural grade, whichever is the lower elevation. Round or square cession footing embedment depths for footings do not apply to locations where walls of the hole will not stand without supplemental support, or where UNCOMPACTED fill of organic fill material exists. Design lateral soil pressure per IBC section 1804.2 for Class 5 soils.
- CONCRETE:
 - All concrete herein required shall be done in accordance with ACI Standard 318-95, "Specifications for Structural Concrete for Buildings", which is hereby made a part of these documents, with the following modifications:

Para 21.2 Concrete shall comply with ASTM C150, Type I, and shall contain no flyash.
 Para 3.2.2.1 shall be 2500 PSI minimum for all concrete at 28 days for all concrete.
 Para 4.1.1 The use of each cut for forms is permitted.
 Para 5.12 Reinforcing shall be new deformed steel complying with ASTM A615, Grade 40. Concrete shall be thoroughly consolidated by suitable means during placement and shall be thoroughly worked around reinforcement and embedded features and into corners of the forms.
 Curing of concrete shall be in accordance with sections 1905.11.1 through 1905.11.3.

Structural Steel:
 All structural steel shall be ASTM A36 (Fy=36,000 PSI) or ASTM A 572 Grade 50 (Fy=50,000PSI). All pipe shall be ASTM A 501 (Fy=36,000 PSI) or ASTM A53, Type "E" or "S", grade "36" (Fy=36,000 PSI). All tubular steel shall be ASTM A501 (Fy=36,000 PSI). All bolts shall be ASTM A325 (Fy=58,000 PSI) and JMS codes apply. All construction per latest AISC Handbook. All expansion bolts to be new current I.C.C. approved. All welding by welders holding valid certificates and having current experience in type of work shown on the drawings or notes. Certificates shall be those issued by and accepted testing agency. All welding by E70 series low hydrogen rods (Use E70 for ASTM A306 - grade 40 reinforcing bars). All welding per American Welding Society Standards.

Drawing scaling requirement:
 These drawings are to be wet sealed by the engineer. All copies shall bear wet seal. If a copy of this drawing is detached without the proper wet seal the drawing is considered invalid. The duplication or copying of this drawing could mean the original drawing has been modified from its original content. All liability is removed from the below wet seal. All wet sealed drawings are signed in BLUE ink and are accompanied with a RED ink "VALID ONLY" WHEN WET SEALED stamp.

Steel Decking / Steel Fasteners:
 Steel roof deck shall conform to the specifications of the steel deck manufacturer. Fy = 80 KSI. Screw connections to framing members shall be not less than noted below:
 1. All Panel End Laps use (6) #12-14 ltk screws per sheet. All Panel intermediate supports use (3) #12-14 ltk screws per sheet.
 2. To all panel tops slitch screws #14-1/2" ltk screws @ 18" o.c.
 3. Panel to un continuous over minimum two spans.
 4. Minimum spacing of screws shall not be less than 3 diameters.
 5. The head of the screw or washer shall have a diameter, dia of not less than 5/16" washers shall be at least 0.05" thick.

All screws shall conform to SAE J78 provisions of structural screws.
 Light Gauge Structural Steel Framing:
 All structural steel framing material and its erection shall be in accordance with the latest edition of the American Iron and Steel Institute Specifications for the Design of Cold Formed Steel Structural Members.
 All welding to be prepared by welders holding a valid certificate and having current experience in light gauge steel. Certificates shall be issued by an accepted testing agency. Do not drill or notch members without prior approval of the structural engineer. All welding to be performed in an approved fabrication shop.
 Structural steel members are furnished to a specified minimum yield point greater than 55 KSI. The grade and the ASTM specification number or other specification designation shall be indicated by pointing, decal, tagging or other suitable means on each fit or bundle of fabricated elements.

Contractor:
 The contractor must submit in writing any requests for modifications to the plans and specifications and no structural changes from the approved plans shall be made in the field, unless prior to making changes, written approval is obtained from the engineer. Shop drawings submitted by the contractor do not constitute "in writing" unless it is noted that specific changes are being requested. If changes are made without written approval, such changes shall be the legal and financial responsibility of the contractor or sub-contractors involved and it shall be their responsibility to replace or repair the condition as directed by the engineer.
 Contractor shall provide all temporary bracing, shoring, guying or other means to avoid excessive stresses and to hold structural elements in place during erection. The provisions shall remain in position until sufficient permanent members are erected to ensure the safety of the partially erected structures. The contract structural drawings and specifications represent the finished structure. Observation visits to the site by the structural engineer shall not include inspection of the above items. The above notes and specifications shall meet or exceed all state and local code requirements before erection.
 The undersigned engineer will not supervise the fabrication or erection of the structure.

Special Inspection:
 Special inspection is to be provided in addition to the inspections conducted by the Department of Building Safety and shall not be construed to relieve the owner or the authorized agent from requesting the periodic and cost inspections required by Sec. 109 of the International Building Code. Special inspection is required for the following:
 1. EPOCH ANCHORS (if APPLICABLE)

| Gauge No. | 12 | 14 | 16 | 18 | 20 | 22 | 24 | 26 | 29 | 30 |
|--------------------------|--------|--------|--------|--------|--------|--------|--------|--------|--------|--------|
| Design Thickness, Inches | 0.1045 | 0.0741 | 0.0598 | 0.0478 | 0.0359 | 0.0299 | 0.0239 | 0.0179 | 0.0135 | 0.0120 |

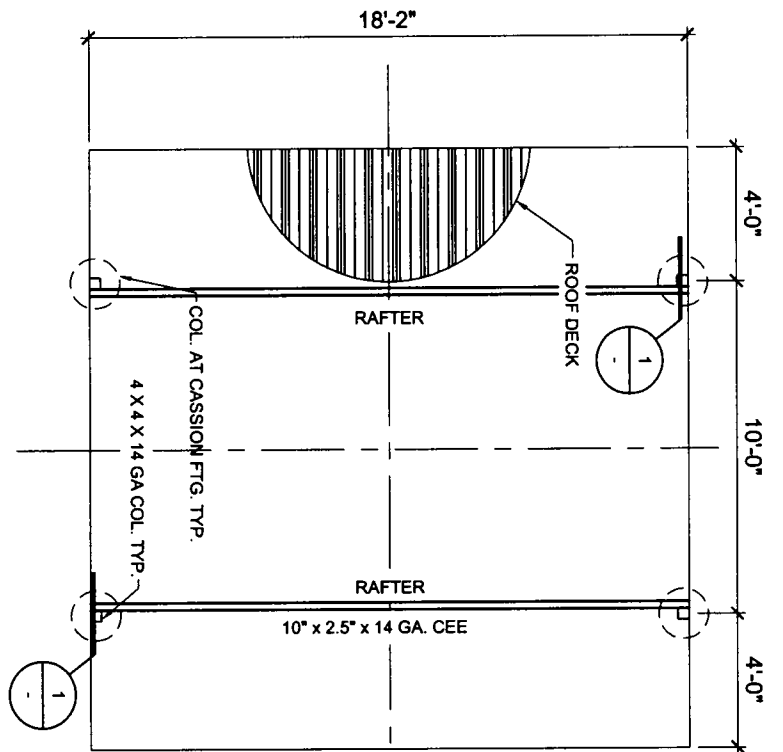

ROOF FRAMING & FOUNDATION PLAN

SCALE: 1/4" = 1'-0"

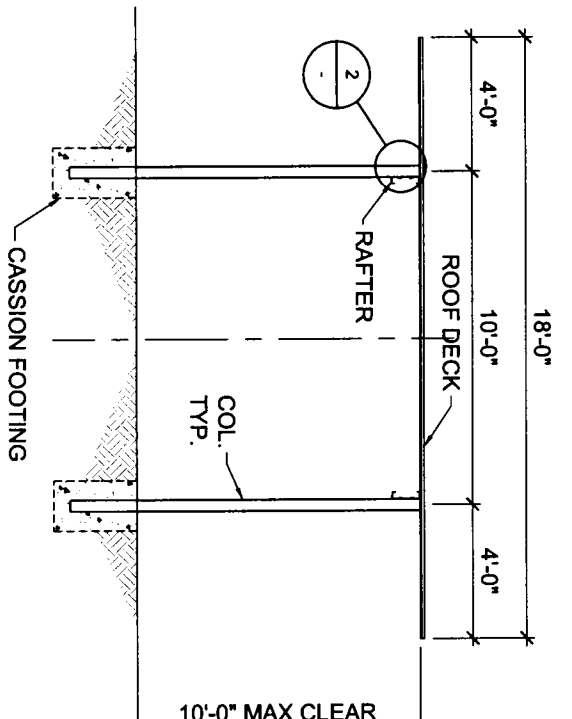

FRONT ELEVATION

SCALE: 1/4" = 1'-0"

PRELIMINARY
 NOT FOR CONSTRUCTION

3 BASE PLATE DETAIL

1" = 1'-0"

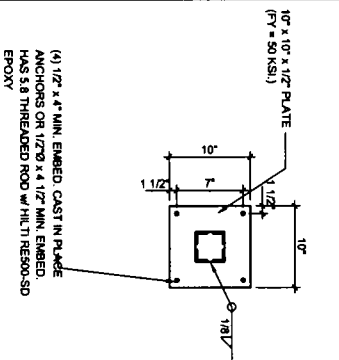

(1) 1/2" x 4" MIN. EMBED. CAST IN PLACE ANCHORS OR 1/2" x 4 1/2" MIN. EMBED. HAS 5/8 THREADED ROD w/ H.L.T.I. RESO.-SD EPOXY

(1) 1/2" x 4" MIN. EMBED. CAST IN PLACE ANCHORS OR 1/2" x 4 1/2" MIN. EMBED. HAS 5/8 THREADED ROD w/ H.L.T.I. RESO.-SD EPOXY

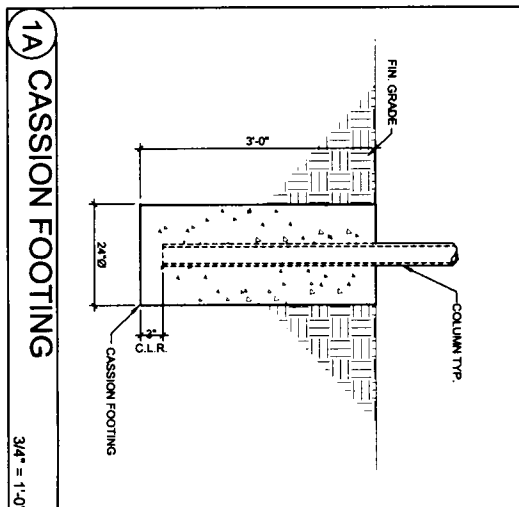

1A CASSION FOOTING

3/4" = 1'-0"

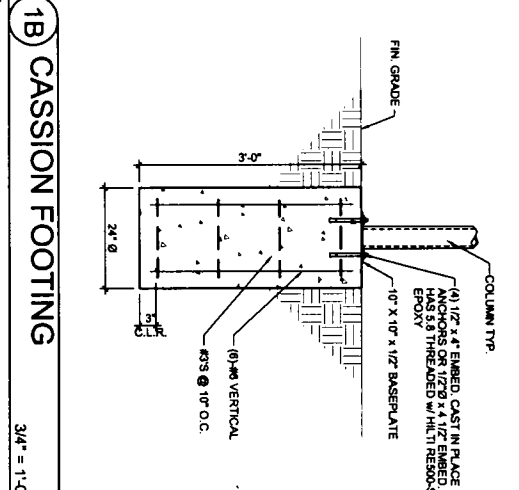

1B CASSION FOOTING

3/4" = 1'-0"

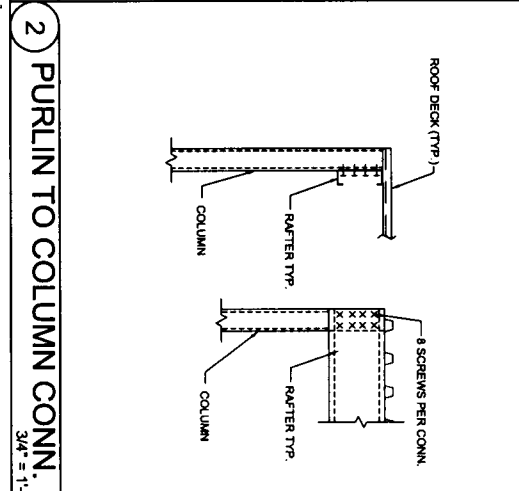

2 PURLIN TO COLUMN CONN.

3/4" = 1'-0"

WESTERN STATES DECKING, INC.
18' x 18' x 10'-0" MAX
4 POST CARPORT
20 PSF, 90 MPH, SEISMIC ZONE 'D'
CALIFORNIA

S. E. CONSULTANTS, Inc.
Structural Engineering Consultants
 5800 East Thomas Road, Suite 104
 Scottsdale, AZ 85251
 Phone: (480) 946-2010
 Fax: (480) 946-1909

sheet **S1** of 1
 design **DEN**
 drawn **RMV**
 check **SWB**
 date **6/26/08**
 job **1269-08**

PLAN VIEWS & ELEVATIONS
DETAILS & PROFILES